

LIQUID CONTROLS SPONSLER



IT400 RATE INDICATOR AND TOTALIZER



- HIGH / LOW ALARMS
- BACKLIGHT
- BATTERY POWERED
- OTHER POWER SOURCES AVAILABLE
- TEMPERATURE COMPENSATION
- 20 PT. LINEARIZATION
- INDEPENDENT RATE INDICATION/TOTALIZATION ENGINEERING UNITS
- MULTI-METER FUNCTIONS TO READ BATTERY VOLTAGE, RTD, FREQUENCY, AND SIMULATE 4-20 MA

SPONSER IT400 RATE INDICATOR AND TOTALIZER

Specifications

Total

- 8 digit 5.40mm high LCD (continuous display)
- Batch total (external reset—magnetic)
- Grand total (no reset)

Rate

- 5 digit 8.66mm high LCD (continuous display)
- Range over/under limit indication
- Refresh rate: multiple depending on power mode (16/s, 8/s, 4/s, 1/s, 0.5/s)

Accuracy

Display: $\pm 0.01\%$ reading (rate) or ± 1 count (total)

Analog output: $\pm 0.025\%$ of full scale @ 20°C

Digital output: ± 1 count

Linearization

- Linearization table, 2-20 points

Power input

Internal

- D lithium battery

Battery life

- Varies—typical per power mode up to 8 years

External

- 48VDC reverse polarity protected

Loop

- 7V load on loop; loop powered from the 4-20mA loop input (non-isolated)

Signal Input (flow)

Magnetic

- Sensitivity: 50mV min. (field adjustable)
- Frequency: 0-3000Hz

RF modulated

- Carrier frequency 50kHz (requires external power or loop power)
- Frequency: 0-3000Hz

Pulse

- Any zero reference or zero crossing wave shape
- Frequency: 0-4000Hz

Temperature Compensation (optional)

- Two wire RTD (10k Ω)
- Coefficient of thermal expansion method

K-Factor range

- Pulses per gallon: 0.0000001 to 999999

Communications

- RS-232 (optional)

Outputs

Scaled Pulse

- Opto-isolated open-collector output
- Frequency or fixed pulse width: (1, 2, 5, 10, 50, 100, & custom ms) output setting
- Output pulse divider: 1, 2, 5, 10, 50, 100, 1000, & custom

Alarm (optional)

- Programmable opto-isolated open-collector output
- Can be used to control totalization

Rate (4-20mA)

- Factored rate to current loop output
- Programmable low and high set points
- Fully isolated (unless loop powered)

Backlight

- Green LED (magnetically activated and timed)

Engineering Unit Display

- Custom descriptors: Gallons, Liters, Ft³, M3, Pounds, BBL, KG (custom weight available)
- Custom units available with given units/gallon
- Rate and Total can have independent unit displays

Enclosure

- Explosion proof aluminum
- FM Approved, CSA Certified
- Class I, Division 1, Groups B, C, & D
- Class II, Division 1, Groups E, F, & G
- NEMA 4
- Weight: 2.5lbs
- Mounts directly on flowmeter

Environmental

- Operating: ≤ 22 to 167°F (-30 to 75°C)
- Storage: ≤ 40 to 185°F (≤ 40 to 85°C)

Compliance

- CE
- UL (pending)
- CSA (pending)

Annunciators

- Dual segment battery level indicator
- Maintenance due indicator
- Temperature range indicator (with temperature compensation option)

Other Features

- EEPROM parameter/setup storage (>100 year retention)
- All features/settings are field programmable. Convenient input via rotary switch and two pushbuttons
- MMC Flash media card data logger (optional—requires RS232)

SPONSLER IT400 RATE INDICATOR AND TOTALIZER

Dimensions

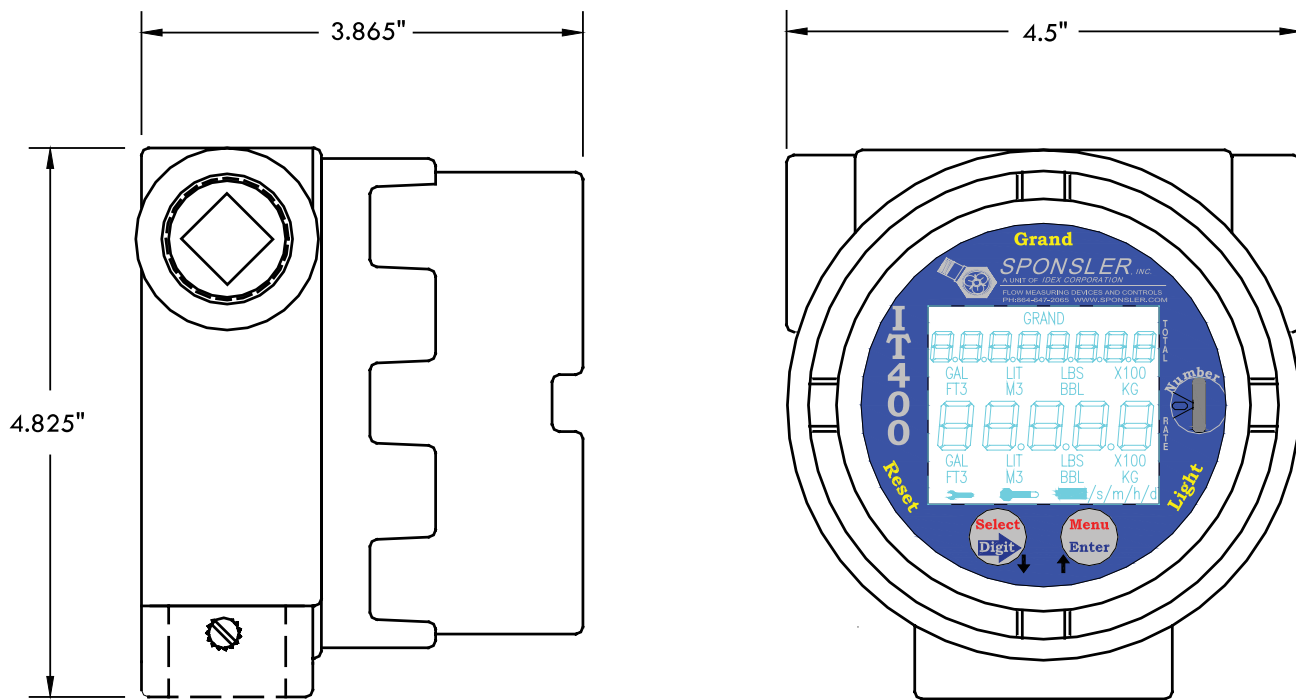

Model Selection Guide

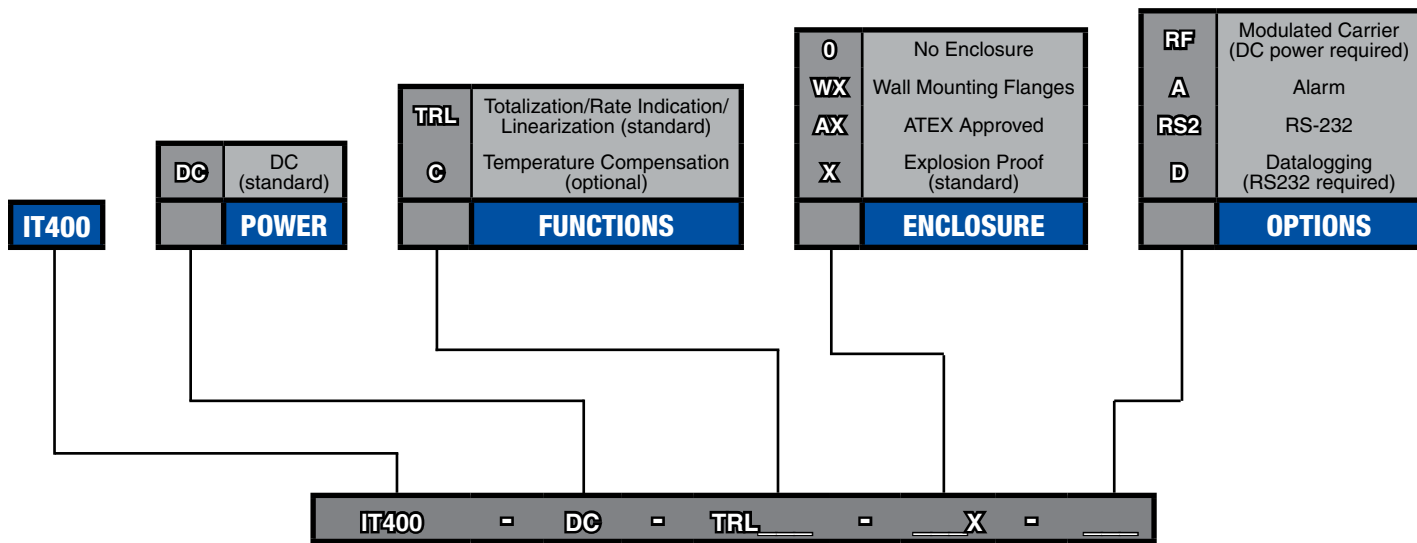

LIQUID CONTROLS GROUP

The Liquid Controls Group provides custody transfer solutions for the control and management of high-value fluids and gases. In 2001, IDEX united Corken, Liquid Controls and Sampi to form the Liquid Controls Group. Together, they used their combined resources to design valuable new products and offer cost-effective pump and meter solutions. The three flagship business units laid the foundation for LCG's successful program of collaboration and innovation. With the additions of Liquid Controls Sponsler, Toptech Systems and Faure Herman, a total of six industry leading brands, LCG quickly became a dependable, single source provider, large enough to supply comprehensive solutions yet flexible enough to customize solutions for unique needs. Today, the Liquid Controls Group has a strong global presence with seven business units in five countries and over 500 distributors on six continents.



YOUR CUSTOMERS — OUR CUSTOMERS

The Liquid Controls Group (LCG) is part of the IDEX Corporation, a diversified, engineered products company. IDEX leverages the resources of high quality, similar-profile businesses to innovate solutions that bring real and lasting value to you, our customer. At LCG and IDEX, the voice of our customers is our driving force. With your guidance, we can preserve the quality of our existing products and develop new products and services that best meet your customers' needs.

LIQUID CONTROLS

105 Albrecht Drive
Lake Bluff, IL 60044
(847) 295-1050

LIQUID CONTROLS EUROPE/SAMPI

Via Amerigo Vespucci 1
55011 Altopascio (Lucca), Italy
+39 0583 24751

LIQUID CONTROLS INDIA

808 VCCI Complex
GIDC Makarpura
Vadodara-390 101
Gujarat, India
+91 265 2631855

LIQUID CONTROLS SPONSLER

105 Albrecht Drive
Lake Bluff, IL 60044
(847) 295-1050

TOPTECH SYSTEMS

1124 Florida Central Parkway
Longwood, FL 32750
(407) 332-1774

Nateus Business Park
Nieuwe Weg 1-Haven 1053
B-2070 Zwijndrecht (Antwerp), Belgium
+32 (0)3 250 60 60

FAURE HERMAN

Route de Bonnetable
B.P. 20154
72406 La Ferté-Bernard Cedex, France
+33 (0)2 43 60 28 60

6961 Brookhollow West Drive
Houston, TX 77040
(713) 623-0808

CORKEN

3805 Northwest 36th St.
Oklahoma City, OK 73112
(405) 946-5576

www.liquidcontrolsgroup.com



Copyright © 2010 Liquid Controls
Publication LT-5009