

# INSTALLATION & OPERATION MANUAL

## T650N SERIES

### CRYOGENIC TRUCK TOTALIZER

DOC #: MN-650.DOC



***LIQUID CONTROLS SPONSLE, INC.***

**FLOW MEASURING DEVICES AND CONTROLS**

**A Unit of the IDEX Corporation**

105 Albrecht Drive • Lake Bluff, IL 60044

(847) 295- 1050 • [www.sponsler.com](http://www.sponsler.com)

**IDEX**  
LIQUID CONTROLS GROUP

# TABLE OF CONTENTS

	Page#
<b>INTRODUCTION .....</b>	<b>3</b>
General .....	3
Theory of Operation .....	3
Testing .....	3
Calibration.....	3
Temperature Compensation-Optional.....	3
<b>INSTALLATION .....</b>	<b>4</b>
Inspection .....	4
Physical .....	4
Electrical .....	4
Signal.....	4
Field Termination .....	4
Initial System Start Up Procedure.....	5
Switch, Adjustment, and Display Descriptions .....	5,6
<b>CALIBRATION .....</b>	<b>6</b>
Sensitivity.....	6
Calibration Factor.....	6,7
“0-1” Function For Calibration .....	7,8
<b>CALIBRATION FACTOR .....</b>	<b>8</b>
Field Correction .....	8
Calibration Factor-Change of Calibration Engineering Units.....	8
Temperature Compensation .....	8,9
<b>MODEL 820 TEMPERATURE COMPENSATOR .....</b>	<b>10</b>
Introduction .....	10
Theory of Operation.....	10
System Setup and Installation .....	11
Calibration.....	11
Model 820 Connection Diagram .....	12
<b>SYSTEM TROUBLESHOOTING.....</b>	<b>13</b>
Procedures .....	13
Troubleshooting Diagram.....	14
<b>MODEL T650N Internal Illustration.....</b>	<b>15</b>
<b>MODEL T650N Dimensional Information .....</b>	<b>16</b>

## INTRODUCTION

### General

The Model T650N Truck Totalizer provides flow totalization in any engineering unit. The totalized flow is displayed via an accumulating 8 digit Liquid Crystal Display (LCD) electronic counter and an 8 digit resettable LCD.

Negatives previously associated with LCD's - poor cold temperature performance, night clarity & condensation, which is a byproduct of heaters, and incandescent lighting - have been eradicated with incorporation of a low temperature coefficient LCD (-30°C) and electroluminescent backlighting. The latest technological advances have been used to develop a precise, reliable totalizer.

### Theory of Operation

The T650N initially amplifies & shapes the incoming pulses generated by the turbine's response to flow. The amplified pulse train is then scaled and divided to produce a totalized display in the desired engineering unit – gallons, liters, pounds, SCF, m<sup>3</sup>, etc. The "power on reset" feature insures that the display is reset to zero during the initial power up sequence. A manual reset function is available if so desired.

### Testing

A single switch "System Test" function enables maintenance personnel to quickly and effectively troubleshoot a system failure, thereby reducing costly maintenance time. "System Test" provides a visual diagnostic indication of every critical function of the T650N. With few exceptions, the system failure will be identified by the fault isolation LED's of the "System Test".

### Calibration

Field calibration is accomplished by incorporating a calibration factor based on the K-Factor of the turbine. A divider switch provides a divisional increment of 10X from 1-10,000. The calibration factor is inserted using 4 BCD switches & the 0-1 dip switch. The calibration factor range is .0001-1.9999. Verification of the electronics accuracy can be accomplished by conventionally utilizing an external oscillator or by depressing the "System Test" switch which applies a calibrated 500 Hz input signal to the system.

### Temperature Compensation – Optional

A microprocessor based temperature compensation system designed to correct flow information based on product temperature is available for use in the T650N. The Model 820 Temperature Compensator accommodates up to 8 different products (field selectable via a rotary switch) and accurately calculates the selected product density acknowledging the non-linearity of the temperature probe and the product.

Installation of the Model 820 Temperature Compensator provides access to wireless I.R. communication for data transfer to the Model SP824 portable ticket printer and provides an output for addition of a PCM-100 module for Pump Control.

After market installation of temperature compensation requires minimal expertise and takes less than 15 minutes to accomplish. By installing the 820 TC module, one connector to the 650 factoring board and the flip of a switch, compensated totalization is accomplished.

## INSTALLATION

### Inspection

All units are completely assembled, tested and inspected at the factory prior to shipment. Upon receipt of the unit, a visual inspection should be conducted to detect any damage that may have occurred during shipment. If the packing case is damaged, notify the local carrier at once regarding his liability. A report should be made to the distributor. Carefully remove the equipment from the packing and inspect for damaged or missing parts.

### Physical

The T650N Flow Converter should be mounted as practically as possible taking into account display visibility, accessibility, etc. Ideally the T650N should be securely mounted using ONLY the supplied shock mounts on a stand positioning the Flow Converter 12-18" above the deck, clear of overhead pipes and as remote from the pump motor as possible. Although the T650N enclosure integrity is watertight at manufacture, adherence to these guidelines will significantly enhance the trouble-free operation of the unit.

### Electrical

The T650N is designed to operate on the 12 VDC power system of the transport and is "polarity insensitive". Both the + and - power inputs should be obtained in the pump control box. To facilitate testing without having to activate the entire pumping system, + power input should be derived from the unswitched 12V input to the pump control box. Every effort should be made to keep the proximity of the Flow Converter's input power leads to the pump motor's winding leads as isolated as practically possible within the pump control box. In the event a transport doesn't have a pump control box, as is the norm in CO<sub>2</sub>, 2 wires should be routed to the trailer's power junction box located at the front of the trailer connected to the 12 VDC accessory or Light Circuit.

DO NOT ATTEMPT TO OBTAIN POWER BY SPLICING INTO THE LIGHT CIRCUIT LOCATED NEAR THE METER: LINE DROPS AND FLUCTUATIONS MAY AFFECT THE UNIT'S OPERATION.

DO NOT CONNECT A JUMPER FROM THE T650N ENCLOSURE TO THE TRAILER CHASSIS AND DO NOT REPLACE THE SHOCK MOUNTS WITH SOLID "LOOK ALIKES" AVAILABLE IN HARDWARE STORES; THEY HAVE SOLID MOUNTING STUDS AND ARE NOT ISOLATING STUDS AS PROVIDED BY THE SPONSLER COMPANY.

### Signal

The standard T650N signal cable is a 2 wire shielded cable with an MS3102 connector termination which is the industry standard interface for 2 pole pickup coils. The shielding is single ended and should not be altered.

### Field Termination

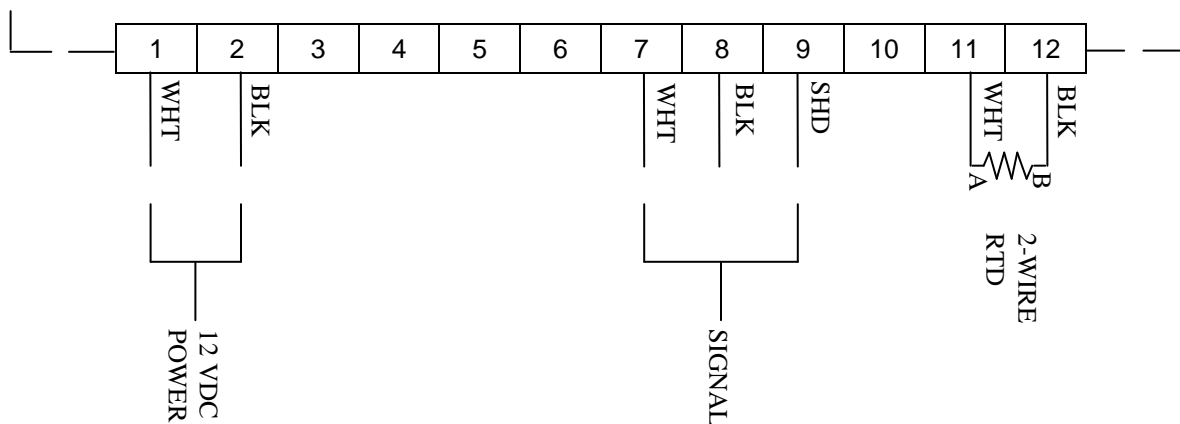



- Bar Graph** - 10 position LED; activated while S9 (system test) is depressed to indicate status of specific functions of the T650N circuitry.
- D1** - normally illuminated; extinguished if either the pickup coil or the signal cable shorts.
  - D2** - normally illuminated; extinguished if either the pickup coil or the signal cable opens.
  - D3** - illuminated if S2 is in "0" position; extinguished if S2 is in "1" position.
  - D4** - normally flashing; nonflashing if mechanical counter output signal is absent.
  - D5** - normally flashing; nonflashing if factoring board output signal is absent.
  - D6** - normally flashing; nonflashing if display board oscillator is not functioning.
  - D7** - normally flashing; nonflashing if system test oscillator is not functioning.
  - D8** - normally illuminated; extinguished if 12 volts is absent.
  - D9** - normally illuminated; extinguished if 5 volts on factoring board is absent.
  - D10** - normally illuminated; extinguished if 5 volts on display board is absent.
  - D11** - Power indicator, LED; illuminated if switched fused input power is present.
  - D12** - TC Range Alarm, LED; illuminated if temperature compensation is incorporated and temperature for the selected product is out of range.
  - J5** - Jumper: installed if external manual reset is incorporated.
  - J6** - Jumper: installed if power on reset is incorporated.

## CALIBRATION

### Sensitivity

The Sensitivity adjust (R1) should be adjusted at the lowest expected flow rate. Turn R1 completely counterclockwise; slowly adjust R1 clockwise until the display increments; then increase R1 slightly clockwise again. In the normal R1 position, the arrow indicator will be in the 11 o'clock position.

### Calibration Factor

The Calibration Factor is derived by taking the reciprocal of the meter's "K-Factor" (pulses per gallon or other engineering unit).

$$C.F. = \frac{\text{Engineering Units}}{\text{K-Factor}}$$

It is desired that zero not be dialed as the first digit on the factor switches. The CF, in most cases, will start with at least one zero. The divider switch (S7) on the factoring board will allow dividing by 1, 10, 100, 1000, or 10000 to move the decimal the required digits.

S7 POSITION	DIVIDER	
1	1	(does not move decimal)
2	10	(moves decimal right 1 place)
3	100	(moves decimal right 2 places)
4	1000	(moves decimal right 3 places)
5	10000	(moves decimal right 4 places)

Example #1: K-Factor = 230 pulses per gallon  
 Engineering Units = Gallons  
 $1/230 = .0043478$   
 Set S7 in Position 3 (100 divider; moves decimal right 2 places)  
 Set S3 at 4, S4 at 3, S5 at 4, S6 at 8 (Rounding 4<sup>th</sup> digit)  
 Set S2 on "0" position

Accuracy: Using the "System Test" the electronic accuracy can be verified incorporating the following formula for a timed test.

$$\text{QTY. Displayed} = \frac{500 \times \text{Time In Seconds} \times \text{Calibration Factor}}{\text{Divider}}$$

Example #2: Time = 2 Minutes (120 sec.), CF = .4348, Divider = 100

$$\begin{aligned} \text{QTY. Displayed} &= \frac{500 \times 120 \times .4348}{100} \\ &= 260.88 = 261 \end{aligned}$$

Universal Formula –

$$\text{QTY. Displayed} = \frac{\text{Hz} \times \text{Time In Seconds} \times \text{Calibration Factor}}{\text{Divider}}$$

### **"0-1" Function for Calibration:**

The "0-1" function provides a greater degree of accuracy when totalization encompasses a large quantity such as SCF produced in a 24 hour period.

Example #3: Assume a turbine flowmeter has a K-Factor of 79.58 pulses per SCF and a product demand of 520,000 SCF is the customer's daily usage.  
 A delivery of 520,000 SCF = 41,381,600 total pulses (520,000 X 79.58).  
 C.F. =  $1/79.58 = .012566$

#### Without the "0-1" function

S7 in Position #2 (10 divider; moves decimal right 1 place)  
 S3 at 1, S4 at 2, S5 at 5, S6 at 7 (rounding the fourth digit)  
 S2 in "0" position

The meter would indicate a total quantity of 520,166.7 SCF

$$\left[ \frac{(41,381,600 \times .1257)}{10} \right] \text{ for a difference of 166.7 SCF}$$

Incorporating the "0-1" function:

S7 in Position #3 (100 divider; moves decimal right 2 places) Decimal must move to the right of the 1 digit.  
 S3 at 2, S4 at 5, S5 at 6, S6 at 6  
 S2 in "1" position

The meter would indicate a total quantity of 520,001.2 SCF

$$\left[ \frac{(41,381,600 \times .2566) + 41,381,600}{100} \right] \text{ for a difference of 1 SCF}$$

## CALIBRATION FACTOR

### Field Correction

To adjust the calibration factor to reflect the actual response of the turbine to the operating conditions, apply the following formula:

$$\text{New Calibration Factor} = \frac{\text{Actual Total}}{\text{Meter Total}} \times \text{Calibration Factor}$$

Example #4: Actual Total = 50  
 Meter Total = 52  
 C.F. = .4000

50/52 X .400 = New Calibration Factor  
 .9615 X .4000 = .3846  
 Insert .3846 into S3 – S6 respectively

In the above example .9615 denotes that the meter is operating 3.85% fast & multiplying the present calibration factor (.4000) by the ratio of Actual Total: Meter Total (.9615) reduces the calibration factor 3.85%.

### Calibration Factor – Change of Calibration Engineering Units

Assume that rather than gallons, liters are the desired engineering unit.

Example #5: K-Factor = 230 pulses per gallon  
 Liters = 3.785 per gallon

$$\frac{3.785}{230} = \text{Calibration Factor}$$

= .016456 for display of liters

Set S7 at 3 (100 divider; moves decimal right 2 places)  
 Set S2 at 1 (incorporates "0-1" function)  
 Set S3 at 6, S4 at 4, S5 at 5, S6 at 6

### Temperature Compensation:

The temperature compensator is discussed in detail in the attached Model 820 Supplement. The Model 820 Temperature Compensator digitally converts a resistive temperature representation to a density correction factor that corrects for variations in mass related to temperature. Incorporation of the following formula provides a means to verify field accuracy.

$$\text{Quantity Displayed} = \left( \frac{500 \times \text{Time in Seconds} \times \text{CF}}{\text{Divider}} \right) \times (\text{Temperature Correction Factor})$$



Use the "System Test" S9 (Injects 500 Hz signal).

Example #6:

$$\begin{aligned}
 \text{Calibration Factor} &= .5279 & \text{Time} &= 60 \text{ seconds} \\
 \text{Divider} &= 100 & \text{T.C. Factor} &= 1.0529 \\
 \text{Substituting: Quantity Displayed} &= \frac{(500 \times 60 \times .5279)}{100} \times (1.0529) \\
 &= \frac{(15837)}{100} \times (1.0529) \\
 &= 158.37 \times (1.0529) \\
 &= 166.7
 \end{aligned}$$

The Temperature Correction Factor (T.C.F.) is referenced at the Normal Boiling Point (NBP). The example above indicates that the product temperature is below the NBP in that the T.C.F. > 1. Likewise, if the product temperature is above the NBP, the T.C.F. will be < 1.

Universal Formula:

$$\text{Quantity Displayed} = \left( \frac{\text{Hz} \times \text{Time in Seconds} \times \text{CF}}{\text{Divider}} \right) \times (\text{Temperature Correction Factor})$$

## MODEL 820 TEMPERATURE COMPENSATOR

### Introduction

The Model 820 Temperature Compensator is a highly sophisticated electronic temperature compensation system designed to correct flow information based on product temperature. Inserted between the signal source and recording electronics, the temperature compensator will automatically add or subtract pulses from the pulse train based on temperature of the product being delivered. The Model 820 is designed to accommodate up to 8 different products (field selectable via a rotary switch) with the density and non-linearity of the temperature probe and each product being acknowledged. Data transfer via wireless (IR) communications is available to print product selection, temperature, correction factor and accumulated corrected total on the Model SP824 Portable Ticket Printer.

### Theory of Operation

As product flows through the pipeline, a turbine located in the product spins and electrical pulses are generated and sent to the temperature compensator. The number and frequency of these pulses corresponds to the amount of product flow and the flow rate.

As the product in the pipeline heats or cools, the density and volume of the product change. When the volume of product changes, the turbine spins faster or slower since the turbine flowmeter is a volumetric measuring device even though the AMOUNT (measured by weight) of product is not changed. Model 820 performs its function first by amplifying and conditioning signals from a pickup coil or other small signal device. The temperature of the product is then read via an RTD temperature probe. Model 820 then adds or subtracts incoming pulses based on the temperature/density of the product and the product's correction curve.

As long as the product flowing past the temperature sensor is within range for the product, the temperature compensator will automatically correct for the density of the product. If the product is not within the correct temperature range, or the temperature probe fails, the compensator will turn on the alarm LED and modify the temperature correction factor (TCF).

The TCF is modified based on the jumper installed at the jumper option block of the 820 (Ref. Drawing SCI-820-CONN-VOL-9-01 & Table "OPTION JUMPER" on the next page). If no jumper is installed, the correction factor will be set for no compensation (TCF = 1.00). If the "B" jumper is installed, the 820 will stop accepting incoming pulses during alarm condition, resulting in no count during an alarm condition. If the "C" jumper is installed, the compensator reverts to 'alarm' temperature and corresponding TCF for the selected product (Ref the 'Model 820 EPROM' table for a listing of products, temperature compensation range, and default alarm temperature).

The pump control output is used in conjunction with the PCM-100 module to disable the pump when the product is above the proper temperature for delivery. If the 820 detects a complete temperature probe failure (temperature reading above 200° C), the pump will be enabled so as not to prevent delivery. A timer to continue to disable the pump after the temperature probe detects that the product is within the correct temperature range for delivery may be activated by installing jumper 'D'. This enabled delay allows the entire system to reach temperature before delivery is allowed. Once the pump is enabled, the product temperature may go out of range for 10 seconds before the pump is disabled. Once the pump is disabled, the initial delay time will be imposed before the pump is again enabled. The delay times are based on the EPROM version installed on the Model 820 and the product selection. The following table lists each version and the associated time delays (The EPROM installed on the 820 will be labeled with the version).

EPROM	PRODUCT	DELAY TIME (minutes)
M820-VO1-9	LOX & LIN	10
	LAR	15
	ALL OTHERS	1
M820-VO1-8	LOX, LIN, & LAR	12
	ALL OTHERS	5
M820-VO1-7	ALL PRODUCTS	5
ANY OTHER VERSION HAS NO TIME DELAY BUILT IN		

### System Setup and Installation

The Temperature Compensator has been calibrated for the RTD and tested in the factory. Once the unit is installed, the product selector switch must be set to the correct position for the product being delivered.

The following table summarizes the various positions of the product selector switch and the corresponding product.

MODEL 820 OPTION 'IC' EPROM					
POSITION	PRODUCT	LOW LIMIT	REF TEMP	ALARM TEMP	HI LIMIT
0	Oxygen	-200.00	-183.11	-168.00	-140.50
1	Nitrogen	-210.00	-195.930	-182.00	-155.30
2	Argon	-189.00	-186.046	-168.00	-140.50
3	CO <sub>2</sub>	-40.050	-16.388	-6.30	-6.30
4	N <sub>2</sub> O	-51.087	-34.679	15.30	15.30
5	Calif. CO <sub>2</sub>	-40.00	-25.817	-7.00	-7.00
6	MAPP	-17.871	15.384	50.50	15.50
7	LPG	-40.00	15.384	49.50	49.50
8	Calibrate & switch test				
9	Self test				

The following table summarizes the option jumpers and their functions. NOTE: Only one jumper should be installed!

OPTION JUMPERS	
Jumper	Description
A	(*do not install) Momentarily shorted in probe calibration mode starts the dip switch verification test.
B	When this jumper is installed the unit will not totalize if the alarm LED is on.
C	When the alarm LED is on... If the jumper is installed the compensator reverts to the 'alarm' temperature and corresponding TCF for the product selected. If the 'C' jumper is not installed, the compensator will set the correction factor for no compensation (TCF = 1.00) and will output the actual temperature without modification.
D	When jumper is installed the pump control time delays will be activated.

### Calibration

To calibrate the unit, first set the product selector switch to position 8 (calibrate). Next replace the temperature probe with a 100 ohm .1 resistor and observe the (-) and (+) LED's on the PCB. If the (-) LED is on, turn the calibrate pot clockwise until the LED goes off. If the (+) LED is on, turn the calibrate pot counterclockwise until the LED goes off. Once both LED's are off, the unit is calibrated properly and is ready for use.

NOTE: Be sure to set the product selector switch back to the correct position for the product being delivered

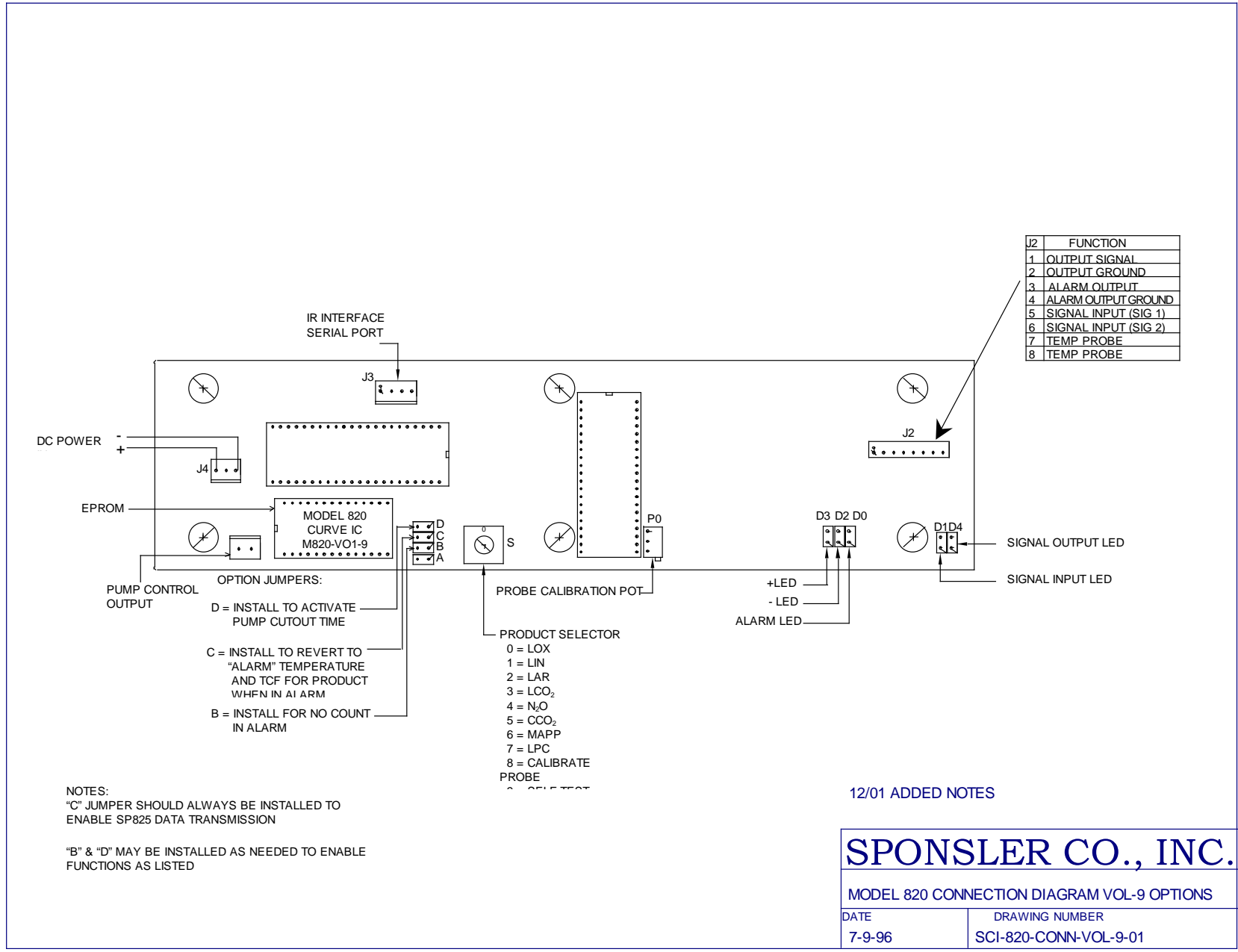

**SPONSLER CO., INC.**

MODEL 820 CONNECTION DIAGRAM VOL-9 OPTIONS

DATE	DRAWING NUMBER
7-9-96	SCI-820-CONN-VOL-9-01

## SYSTEM TROUBLESHOOTING

### Procedures:

When a failure is believed to exist, the following procedure will aid in expediting the isolation of the failure.

1. Check all wiring for secure and accurate connections. Ref. DRAWING # T650NIR-1
2. Check that sensitivity (R1) setting is mid-range (11 o'clock), and depress S9. Observe all LED's and the displays.
3. Follow the troubleshooting diagram (next page) for the following:

### SYMPTOM

No Display  
Display "ON" – No Count  
Display Counts – No Accumulative Count

This test is designed to troubleshoot the 820 Temperature Compensator after the 650D and 650F Boards have been proved functional (unit functions correctly when S12 is in W/O TC position).

Refer to Drawings:     SCI-820-CONN-VOL-9-01  
                              T650NIR-1  
                              Troubleshooting Diagram

### Preliminary Checks:

1. Probe Cable: Check continuity between Pin A and WHT wire; Pin B and BLK wire.  
Check NO SHORT between Pin A and Pin B or between Pin A or Pin B and the connector.  
Insure that the probe cable wires are securely attached at J1-11 and J1-12.
2. Probe: Check resistance between Pin A and Pin B  
If the RTD is at ambient temperature, resistance range 100 to 110  
If the RTD is immersed in liquid product at delivery temperature:  
    LOX resistance range 18 to 42  
    LIN resistance range 16 to 37  
    LAR resistance range 23 to 42  
    CO<sub>2</sub> resistance range 84 to 96  
If the resistance reading is NOT within the specified range, replace the RTD
3. Insure that interconnect wiring harness is installed properly and securely at 650F J2-A and 820 J2 and J4.
4. Insure that the 820 Product Selector Switch (SO) is in proper position for product being measured.
5. Check placement of jumper on 820 PCB. Ref DRAWING # SCI-820-CONN-VOL-9-01. If installed at 'B', the unit will not count while the temperature is out of range for the selected product. The alarm LED will be "ON" if the temperature is out of range.
6. Set S12 in W/TC position. Turn Power "ON". Display is "ON"; D11 is "ON"; D12 is "OFF" (Probe is immersed in liquid product). Depress S9. If D3 and D4 don't flash (unit does not count), proceed to Troubleshooting Chart (next page).

TROUBLESHOOTING DIAGRAM

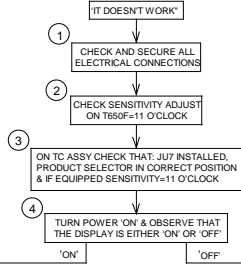

- T.C. 100Ω CALIBRATION PROCEDURE  
 A) DISCONNECT RTD  
 B) INSTALL TEMP CAL PLUG  
 C) SET PRODUCT SELECTOR ON T.C. TO #8  
 D) CALIBRATION ADJUSTMENT- D2 'ON' (-) ADJUST UNTIL D2 'OFF'  
 D3 'ON' (+) ADJUST UNTIL D3 'OFF'  
 E) DISCONNECT TEMP CAL PLUG  
 F) CONNECT RTD  
 G) RETURN PRODUCT SELECTOR ON T.C. TO CORRECT PRODUCT  
 0 = O<sub>2</sub>  
 1 = N<sub>2</sub>  
 2 = Ar

- BASIC CONCEPTS  
 1) DISPLAY 'ON'  
 2) ALL DIAGNOSTIC LEDS 'ON' OR 'FLASHING'  
 3) ALL T.C. RANGE LEDS 'OFF'  
 4) DISPLAY COUNTS  
 5) SYSTEM ACCURACY  
 6) VAPOR BLOW BY GENRATES COUNT

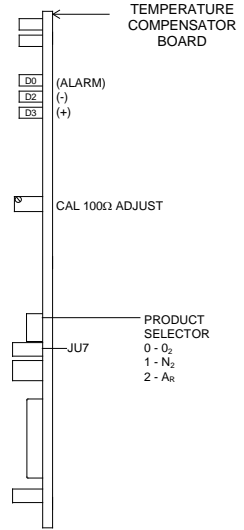
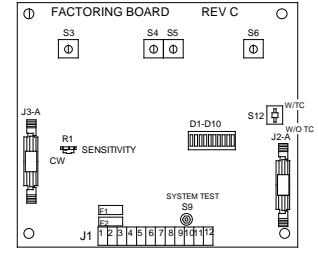
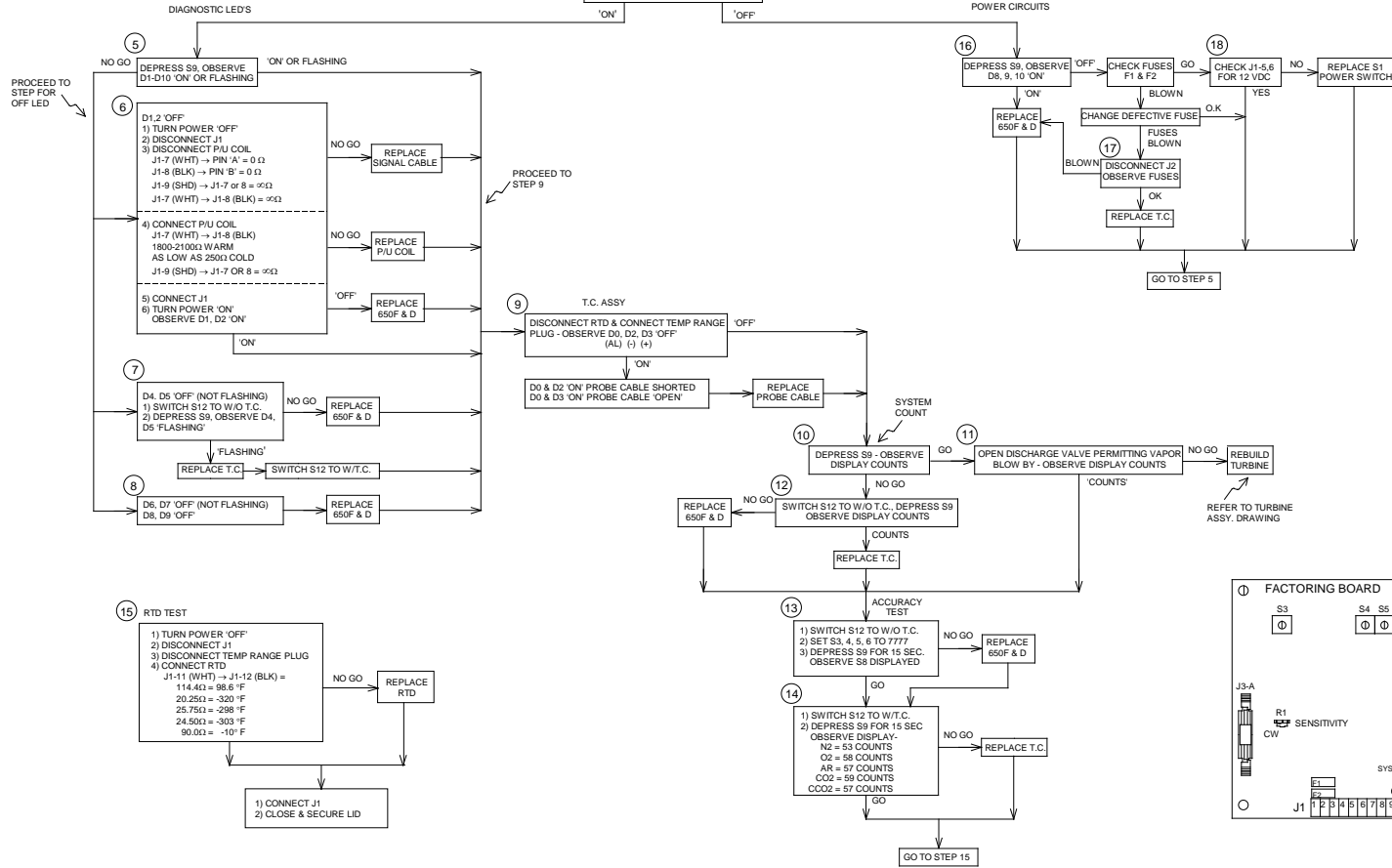



**Dimensional Information**

